

A glowing dodecahedron made of many small, multi-colored LEDs. The lights are arranged in a grid on each face, creating a vibrant, multi-colored glow. The background is dark, making the lights stand out.

# What I learned from making an 1836\* LED dodecahedron

\*It's actually just 612 RGB LEDs but thanks for watching

# Who am I?

- hoarder of things, maker of stuff
- 3 MCUs per project in a drawer
- 105 public projects on hackaday
- more on Mastodon:  
@davedarko@chaos.social

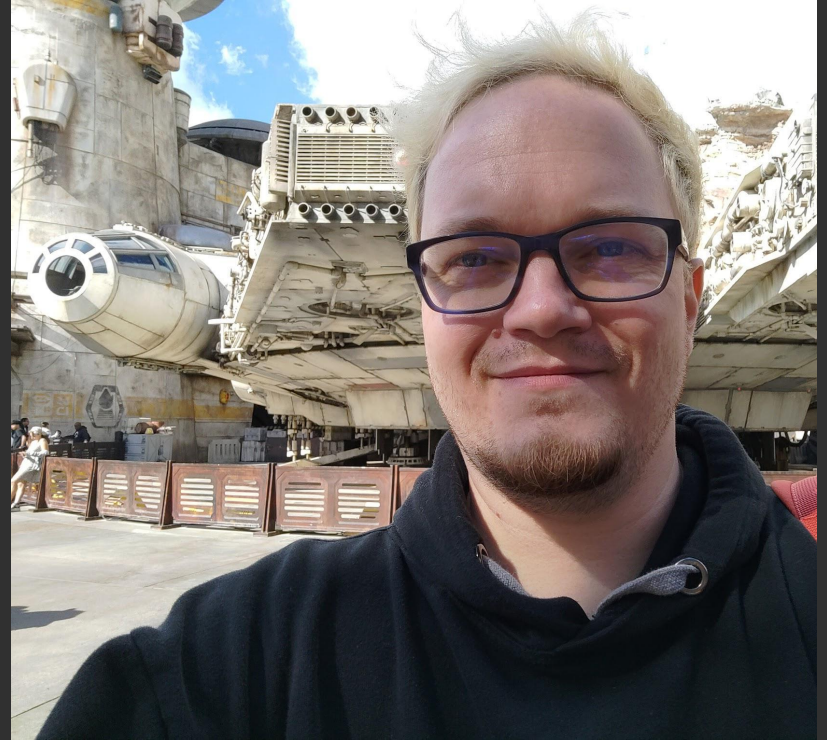

You May Remember Me  
From:

# unfinished PCB replacement for calculator watch

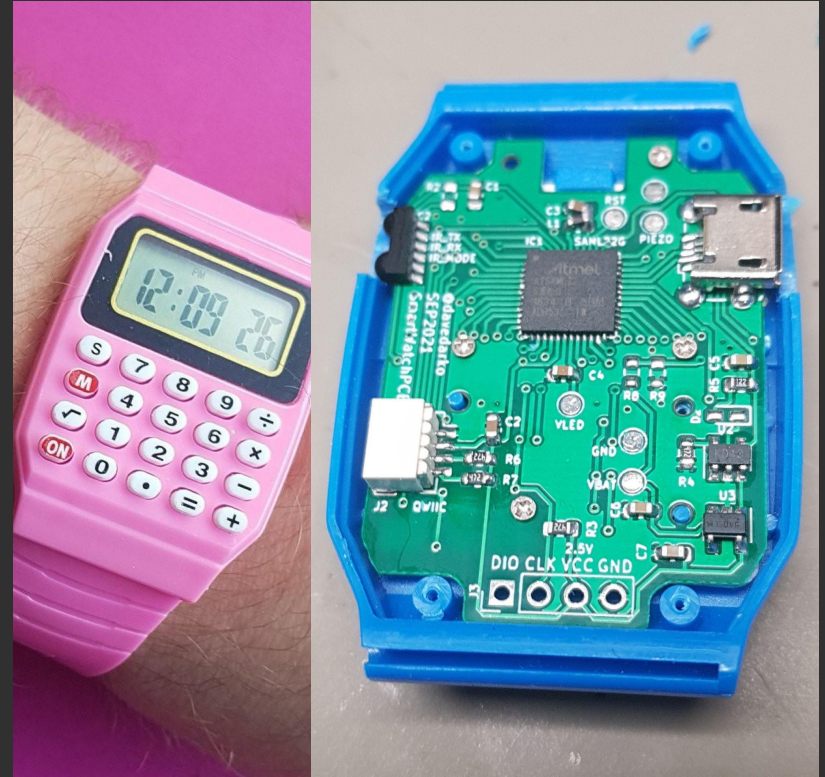

<https://hackaday.io/project/180832-new-pcb-for-calculator-watch>  
<https://hackaday.com/2021/08/01/living-the-dream-new-pcb-for-a-dirt-cheap-calculator-watch/>

You May Remember Me  
From:

# unfinished WIFI Game Boy Cartridge



<https://hackaday.io/project/20769-wifi-game-boy-cartridge>  
<https://hackaday.com/2017/05/14/hackaday-prize-entry-wifi-game-boy-cartridge/>

You May Remember Me  
From:

# unfinished Sp4c3 Inv4d3rs LED handheld



<https://hackaday.io/project/165299-led-handheld>



2270962A-Y11-211215

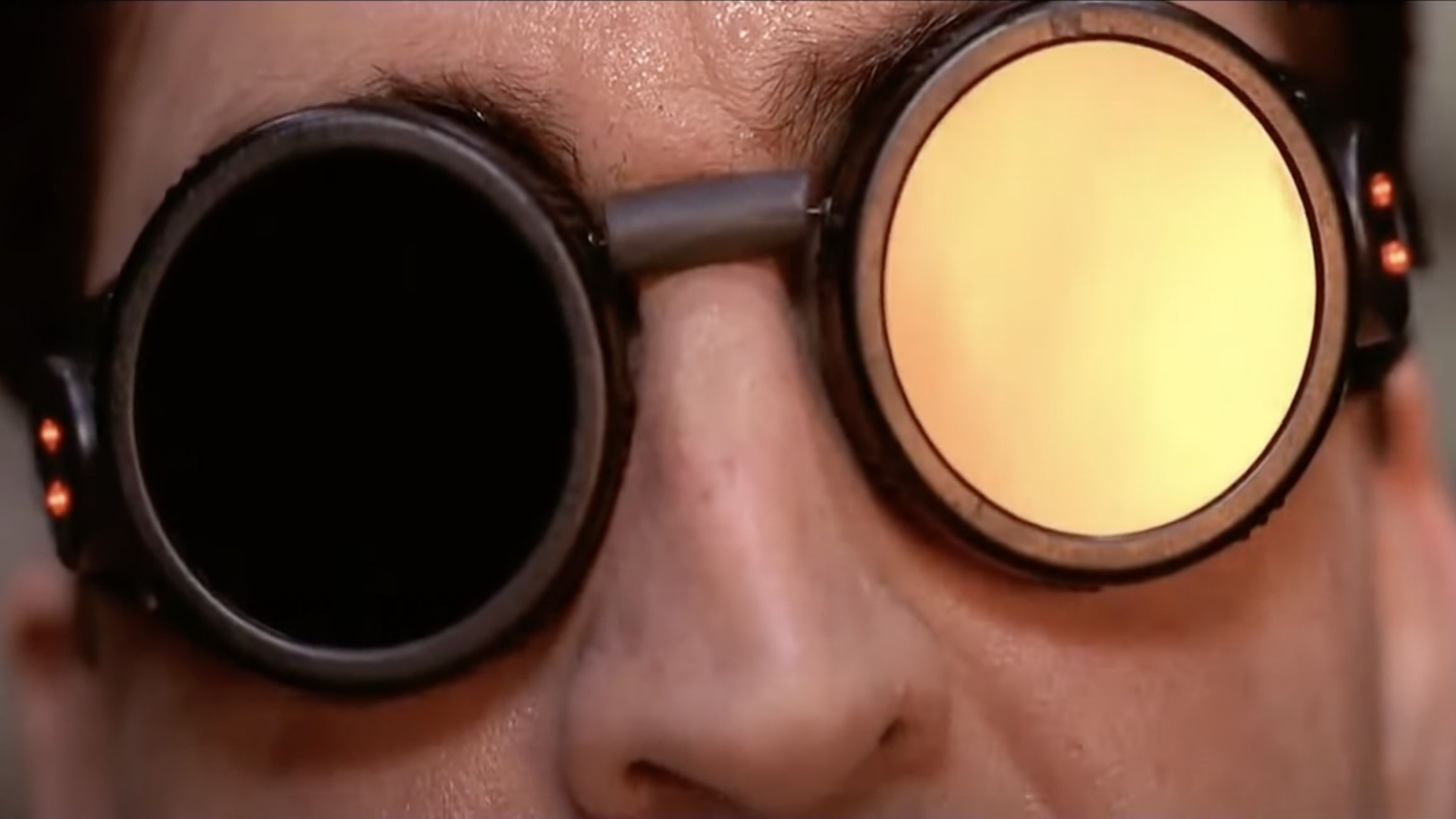

# But Why?

Greg Davill's D20 2400 LED cube at hackaday supercon and later 36C3

<https://gregdavill.com/posts/d20/>

Combined assembly of xHain hack+makespace, c-base and CCCB at 36C3 featured a 2m dodecahedron with 1m LED strips for edges





# Dodecahedron fun facts

- one of five platonic solid
- body with 12 sides
- sides are pentagons (5 sided shapes)
- angle in pentagon are all 72 degrees
- angle between two intersecting planes is called dihedral angle
- dihedral angle of dodecahedron is  $116.56505^\circ = \arccos(-1/\sqrt{5})$



# Hardware decisions - y u no neopixels?

## Neopixels | Dotstars

- adafruit terms for WS2812 and SK9822
- contain small IC within LED
- set color to (0,0,0) and current consumption is still 1mA
- 612mA without showing anything

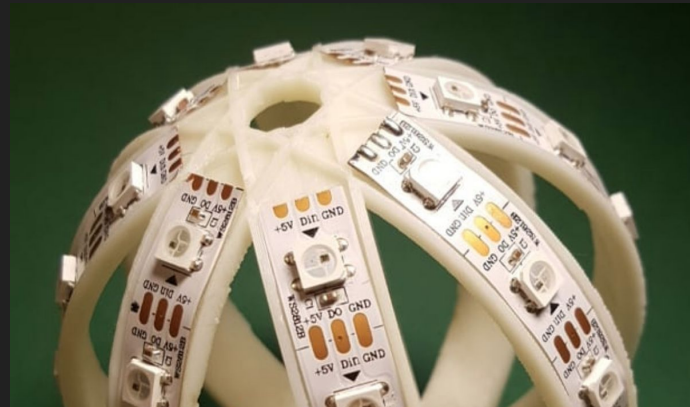

## IS31FL3733

- has up to 16 possible I2C addresses
- I2C means 4 wires from PCB to next
- single IC with global brightness setting
- can talk I2C at 1MHz

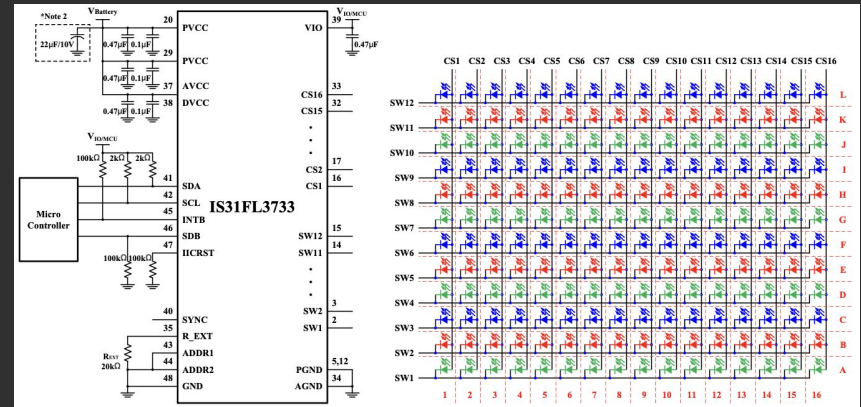

# Hardware decisions - controller

## XIAO NRF52840 Sense

- 6-axis Inertial Measurement Unit (IMU)  
LSM6DS3TR
- Pulse Density Modulation (PDM) Digital  
Microphone
- integrated charger (50mA)
- 400kHz I2C max\*
- Bluetooth 5.0

## ESP32 based boards

- Adafruit QT Py ESP32-S2
- XIAO ESP32C3
- no extras onboard
- 1 MHz I2C max
- Bluetooth 5.0 and Wi-Fi

\*datasheet implies 400kHz max, but byte higher rates seem possible from I2C configuration section

# Arranging LEDs

- LEDs =  $1+5*(n+...+1)$
- 

n	LEDs	chips	free pins	chips %	LEDs total	chips total
1	6	1	58	9,4	72	12
2	16	1	48	25,0	192	12
3	31	1	33	48,4	372	12
4	51	1	13	79,7	612	12
5	76	2	52	59,4	912	24
6	106	2	22	82,8	1272	24
7	141	3	51	73,4	1692	36
8	181	3	11	94,3	2172	36
9	226	4	30	88,3	2712	48
10	276	5	44	86,3	3312	60
11	331	6	53	86,2	3972	72
12	391	7	57	87,3	4692	84
13	456	8	56	89,1	5472	96
14	526	9	50	91,3	6312	108

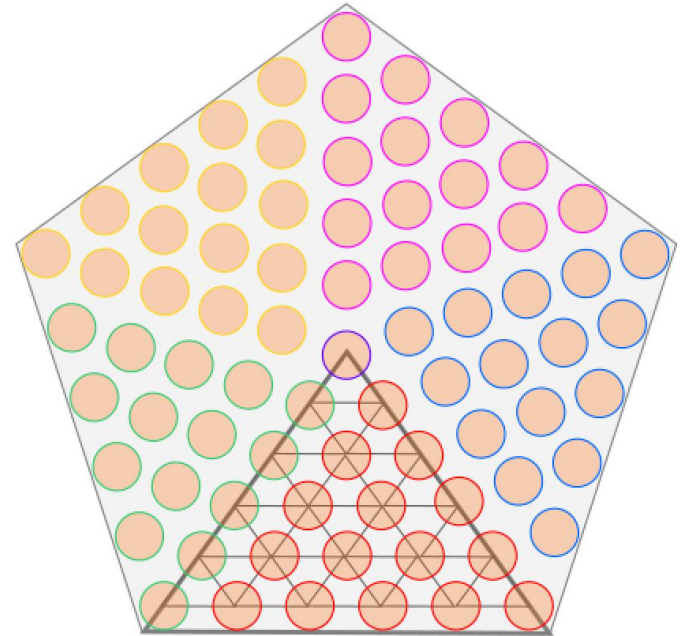

# PCBA - PCB + Assembly

- JLCPCB pcb and single sided assembly of LEDs
- first 4 layer board
- had to start over
- they noticed LEDs were populated upside down
- had to order 15 populated boards
- populated 4 layer boards green only :(

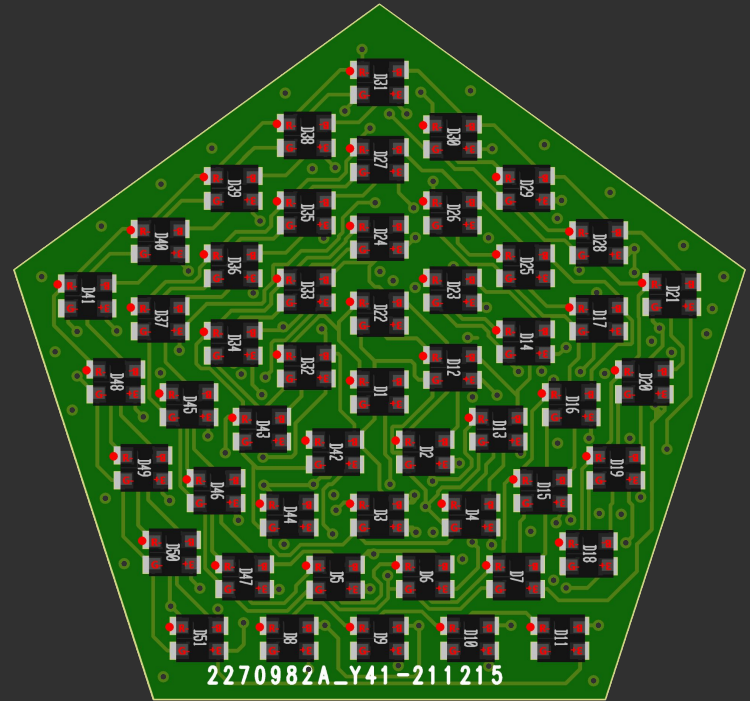

# General PCB tips

- KiCad actually tells you that D25 Pin 4 is not connected
- always run DRC even if you just did
- don't forget to check "remove order number"
- don't order after midnight

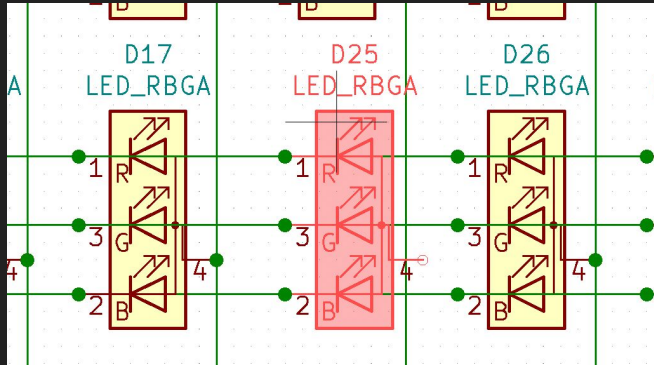

# What if... no DRC?

- well why didn't you?
- enamel wire to the rescue
- repeat 14 times

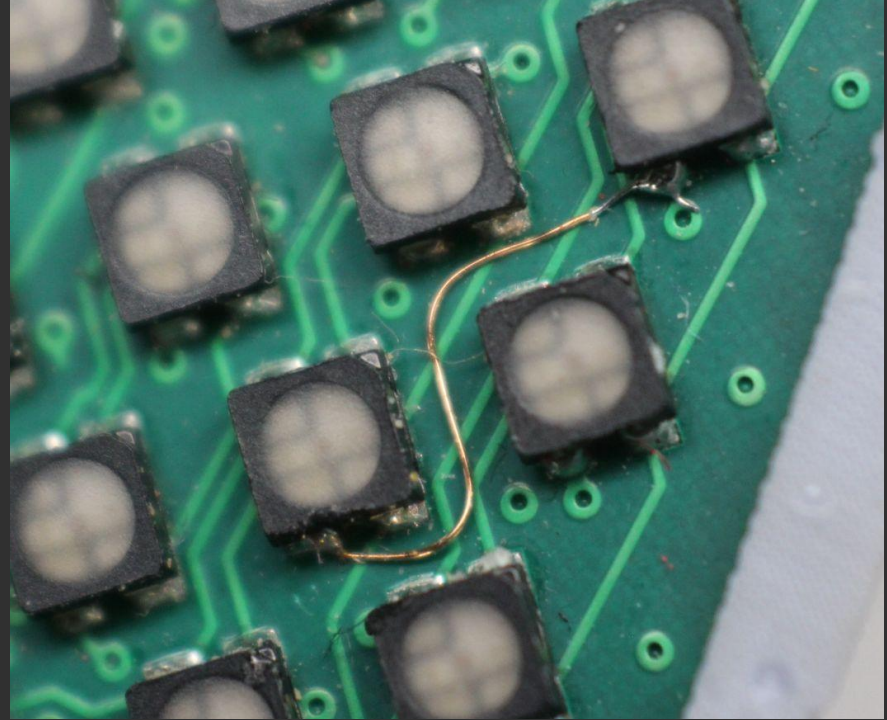

# Debugging the backside

- backside voltage fix
- show led leg fix
- keep LED legs for fixing PCBs
- add more capacitors
- reduce brightness value

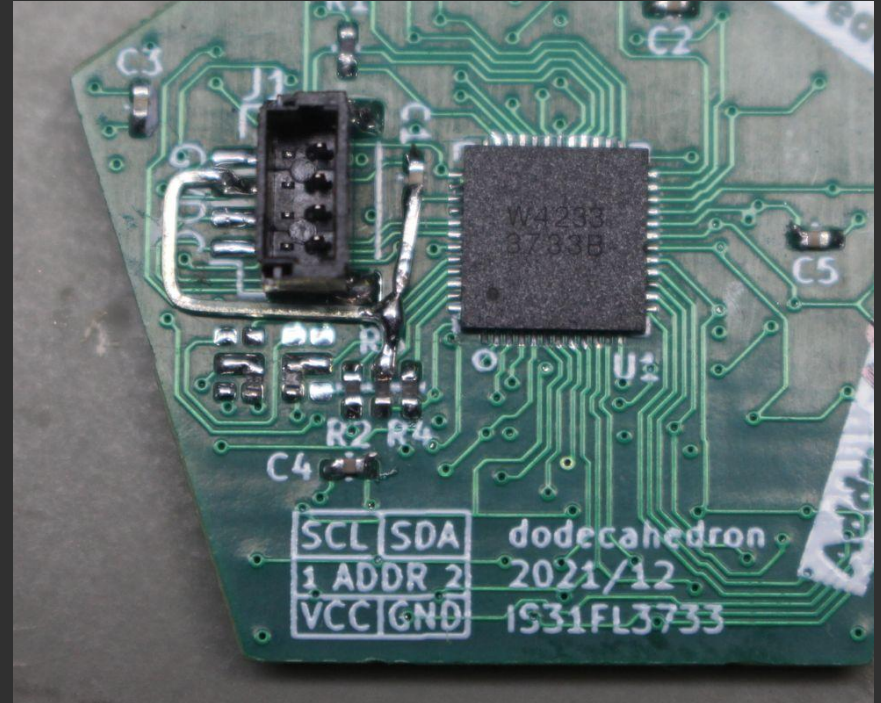



# 2D to 3D

- resin printing sucks
- made a snap-fit design to hold the PCBs
- ten 1mm x 1mm magnets for holding half-shells together

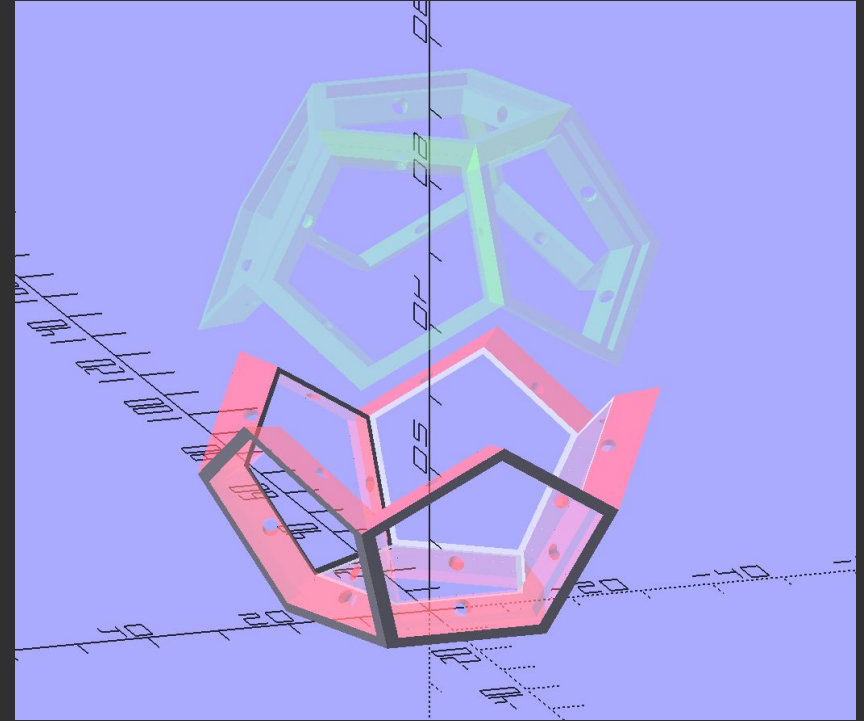

# What's the max frame rate?

I2C communication for byte	1 byte + 1 ACK bit	9 bits
I2C speed		400 kHz
Just LED Data	12 PCBs x 64 LEDs x 3 RGB	2304 bytes
Bytes to send with ACK bit		20,736 bits
max frames per second	400kHz / 20,736 bits	<b>19 FPS</b>

additionally 3 bytes for “set PWM register page” and two for “set PWM data

# Software issues

- redundant library was redundant
- sent 6 bytes per LED color
- frame rate of roughly 2 fps
- data “burst” was disabled in code
- after debugging 10fps achieved
- off to the scope

## REGISTER CONTROL

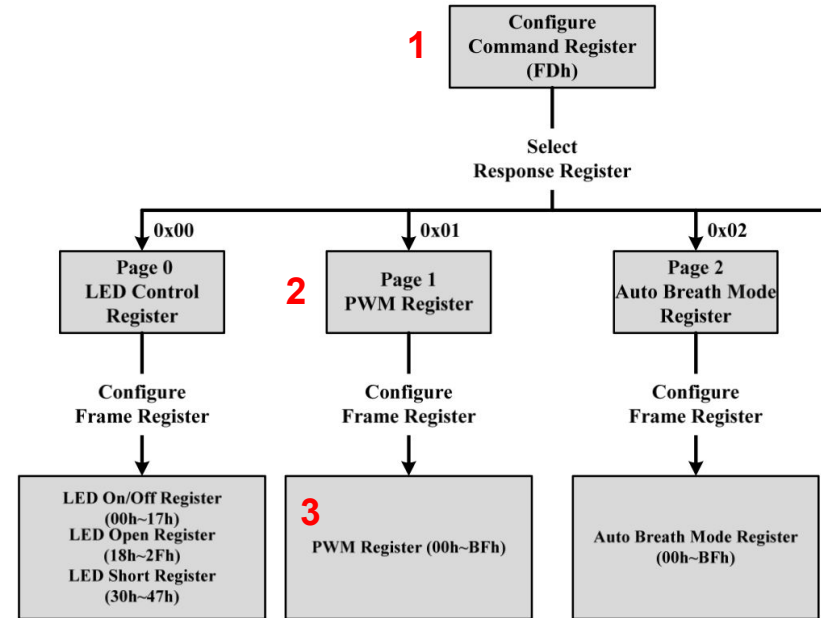

RIGOL DS1054 Z

OSCILLOSCOPE UltraVision

4 Channel  
50MHz 1GS/s

RIGOL STOP H 10.0us 500MS/s 60.0k pts

D 64.600000us

T  $\$$   $\square$  -250mV

Horizontal



Period



Freq



Rise Time



Fall Time



+Width



-Width



- Decoder
- I2C
- Decode
- OFF
- CLK
- CH1
- DATA
- CH2
- Exchange
- CLK/DATA
- CopyTrig

Period=7.400us Freq=135kHz

1 = 2.00V 3 = 1.00V 4 = 1.00V

# Hardware Issues 2 - I2C

- 5us means frequency of 200 kHz
- the IS31FL3733 stretched the clock
- all spikes are far from being square
- turns out **pull-up resistors** are a thing
- 400kHz after adding 2.2kOhm resistors
- smoOOoth 16 fps

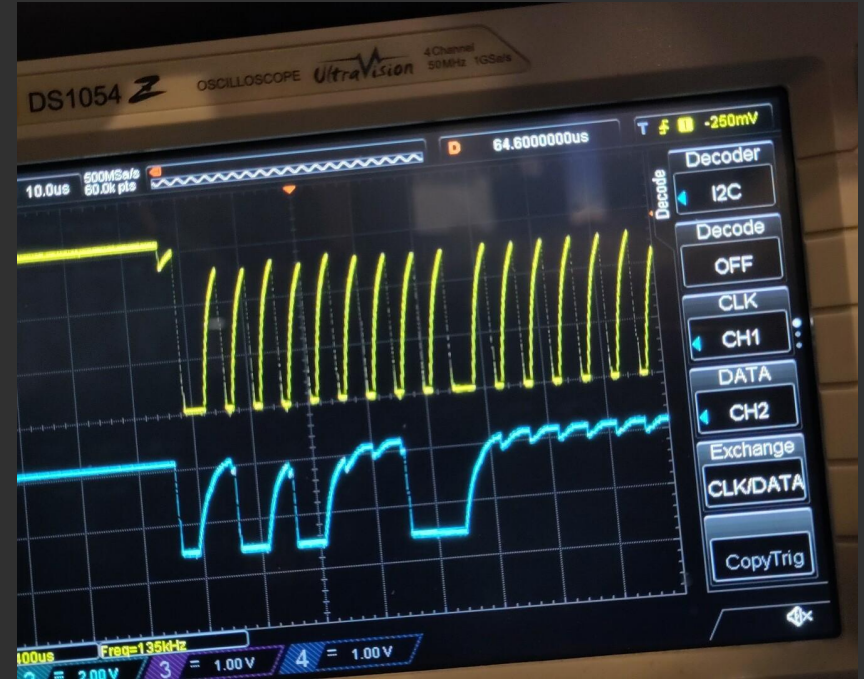

# Expenses

	BOUGHT	PAID	per module	per piece	per Module
<b>TOTAL</b>		<b>206,49 €</b>			<b>12,30 €</b>
PCBs	15	36,79 €	1,000	2,45 €	2,45 €
stencil	100	7,24 €	1,000	0,07 €	0,07 €
assembly	15	25,28 €	1,000	1,69 €	1,69 €
IS31FL3733	15	37,80 €	1,000	2,52 €	2,52 €
cap104	500	5,50 €	3,000	0,01 €	0,03 €
cap474	50	12,30 €	2,000	0,25 €	0,49 €
Adafruit 50mm	12	15,72 €	1,000	1,31 €	1,31 €
jst connector	30	10,38 €	2,000	0,35 €	0,69 €
mouser ship/tax	15	15,71 €	1,000	1,05 €	1,05 €
jlc tax/ship	15	14,27 €	1,000	0,95 €	0,95 €
magnets	50	10,00 €	2,000	0,20 €	0,40 €
battery	2	15,50 €	0,083	7,75 €	0,65 €

# Benefits: socialising with and through solids

@charlyn@leds.social



@geekmomprojects@mastodon.social



# Benefits: platonic comparison





# future

- just needs a bit of mapping needed
- integration of microphone and IMU
- changing I2C clock
- C3woc inspired iteration?



find project here

<https://hackaday.io/project/169691-ledodecahedron>

<https://github.com/davedarko/LEDodecahedron>



# find me here

xHain hack+makespace  
@davedarko:x-hain.de

@davedarko@chaos.social

hackaday.io/davedarko

